

## Summary

Jurisdiction: City of Roseville  
 Plan: Del Webb Specific Plan  
 Zone: Community Commercial (C2-SA)  
 Land ±8.7 AC ±379,241 SF  
 Building 75,872 SF  
 Coverage 20%

**Parking Required:**  
 Market 55,592 sf (1/300 sf) 185 stalls  
 Shops 1 Retail 9,950 sf (1/300 sf) 33 stalls  
 Shops 1 Rest. 4,200 sf (1/100 sf) 42 stalls  
 Pad A Retail 830 sf (5 space min.) 5 stalls  
 Pad B Rest. 5,500 sf (1/100 sf) 55 stalls  
**Total Parking Required: 320 stalls**

**Parking Provided:**  
 (C) Compact 37 stalls  
 (GC) Golf cart 15 stalls  
 (HC) Handicap Standard 13 stalls  
 Standard 224 stalls  
**Total Parking Provided 326 stalls**  
**Parking Ratio 4.29/1000**

**FUTURE CLEAN AIR VEHICLE (CAV)/EV PARKING:**  
 (per Cal Green Code CAV table 5.1065.2 & EV table 5.1065.3.3)

CAV (12% of total req. parking) 6 stalls  
 EV (10% of total req. parking) 33 stalls

**Bike Parking Provided:**  
 Short-Term 12  
 Long-Term 4



Vicinity Map  
 Not to Scale

ALL BUILDINGS, IMPROVEMENTS, THEIR OCCUPANTS AND THE USES AS SHOWN ON THIS PLAN ARE PRELIMINARY AND SUBJECT TO MODIFICATION AT THE OWNER'S DISCRETION WITHOUT NOTICE.

THIS PRELIMINARY SITE PLAN IS BASED ON INFORMATION FURNISHED TO NADEL ARCHITECTS INC AND IS SUBJECT TO VERIFICATION BY LEGALS, SURVEYS AND GOVERNING AGENCIES ETC. THIS EXHIBIT IS NOT NECESSARILY A REPRESENTATION AS TO IDENTITY, TYPE, SIZE, LOCATION, TIMING OR OCCUPANCY OF ANY BUILDING WITHIN THIS CENTER.

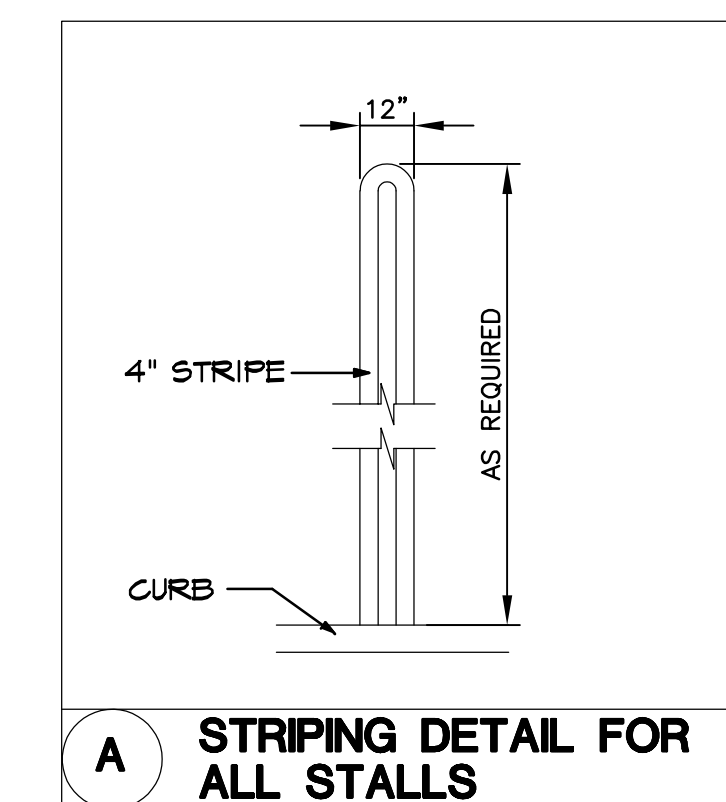

A STRIPING DETAIL FOR ALL STALLS

CITY OF ROSEVILLE APPROVAL

# PRELIMINARY SITE PLAN WEST ROSEVILLE MARKETPLACE 1798 PLEASANT GROVE BLVD., ROSEVILLE, CA

## SHEET C1.1

JOB #: 22002  
 DATE: 03/15/2022  
 REV. 08/16/2022

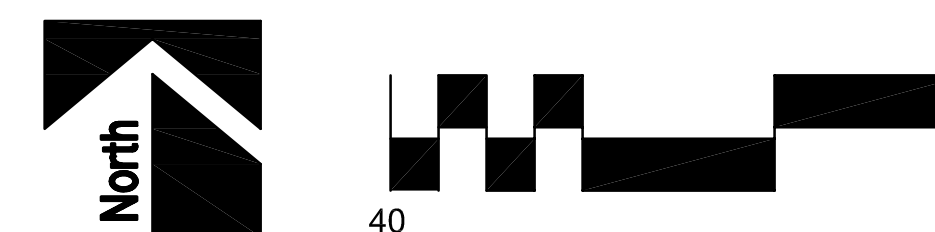

NADEL STUDIO ONE, INC.  
 1990 S. BUNDY DR., SUITE 400  
 LOS ANGELES, CA 90025  
 T: 310.826.2100 F: 310.826.0182  
 WWW.NADELARC.COM

